

**MATERIAL**

Glass-fibre reinforced polyamide based (PA) technopolymer, black colour, matte finish.

**STANDARD EXECUTIONS**

Black-oxide steel boss, H9 reamed hole.

- **MT-AT**: with revolving handle 1.621+x (page 500) in technopolymer, not removable.
- **MT-AT+IR**: with fold-away handle IR.620 (page 508) in technopolymer.

**FEATURES AND APPLICATIONS**

The reticular structure of the crank arm and the technopolymer used make this handle very strong and therefore suitable for transmitting high torque values.



ELESA Original design

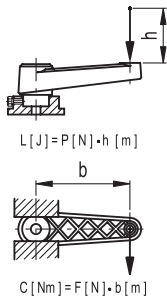

Conversion Table	
1 mm = 0.039 inch	
R	
mm	inch
50	1.97
64	2.52
80	3.15
100	3.94
130	5.12
160	6.30

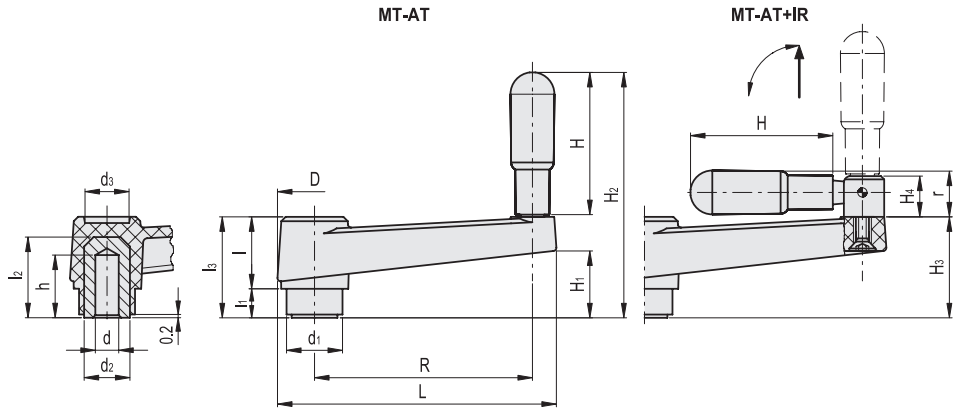

MT-AT		<b>METRIC</b>																	
Code	Description	R	dH9	L	D	d1	d2	d3	l	l1	l2	l3	h	H	H1	H2	C# [Nm]	L# [J]	⚖️
44053	MT.50-AT	50	6	69	22.5	18	15	13	20.5	9	23	29.5	18	35	18.5	66	80	7	55
44113	MT.64-AT	64	8	86	26.5	20	15	16	22.5	9	25	31.5	20	45	17.5	78	120	11	82
44213	MT.80-AT	80	10	106	30	24	18	17	26	11	31	37	25	60	23.5	99	200	15	118
44313	MT.100-AT	100	12	128	33.5	24	18	21	30.5	10	31	40.5	24	65	25	106	210	27	190
44413	MT.130-AT	130	14	162	39	34	26	25	35	14	43	49	30	65	32.5	113	350	45	335
44513	MT.160-AT	160	16	197	44	34.5	26	27	39.5	15	43	54.5	30	80	36	136	470	55	375

MT-AT+IR		<b>METRIC</b>																			
Code	Description	R	dH9	L	D	d1	d2	d3	l	l1	l2	l3	h	H	H1	H3	H4	r	C# [Nm]	L# [J]	⚖️
44117	MT.64-AT+IR	64	8	86	26.5	20	15	16	22.5	9	25	31.5	20	45	17.5	31	14	16	120	11	89
44217	MT.80-AT+IR	80	10	106	30	24	18	17	26	11	31	37	25	60	23.5	37	14	16.5	200	15	130
44317	MT.100-AT+IR	100	12	128	33.5	24	18	21	30.5	10	31	40.5	24	65	25	39	18.5	20.5	210	27	200
44417	MT.130-AT+IR	130	14	162	39	34	26	25	35	14	43	49	30	65	34	49	18.5	20.5	350	45	330
44517	MT.160-AT+IR	160	16	197	44	34.5	26	27	39.5	15	43	54.5	30	80	36	54	18.5	22	470	55	370

# For maximum torque (C) and impact strength (L) see Technical data on page A-3.

